

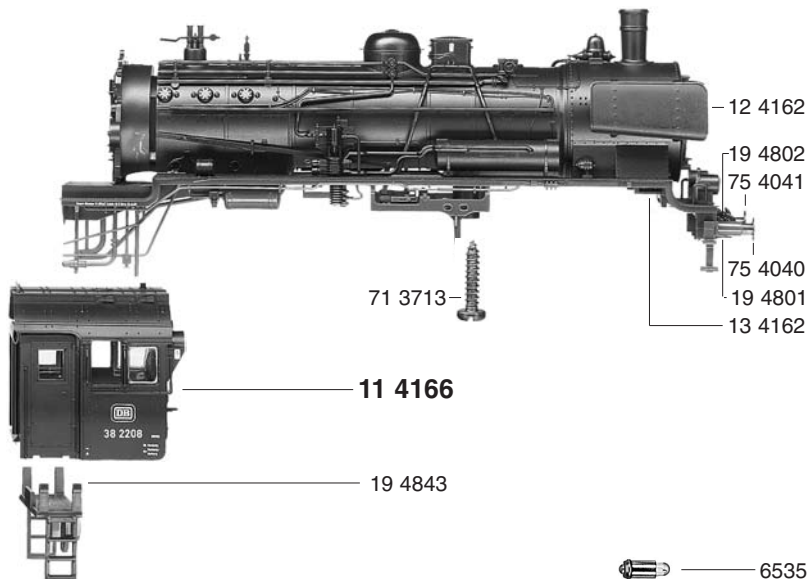

10 4166



- 10 4166 Lokgehäuse kpl.
- 11 4166 Führerhaus kpl.
- 12 4162 Windleitbleche (Satz)
- 13 4162 Lichtleiter (Satz)
- 19 4801 Bremsschlauch
- 19 4802 Kupplungshaken
- 19 4843 Führerhaus-Trittstufen

30 4166

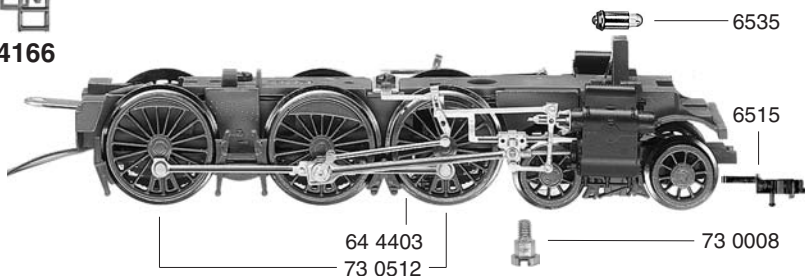

- 30 4166 Lokfahrgestell kpl.
- 31 4160 Abdeckplatte
- 32 4166 Steuerung kpl. mit Kuppelstangen
- 33 4161 Zylinderkasten
- 34 4160 Kuppellasche mit Federn (Satz)
- 37 4160 Vorlaufgestell kpl.
- 38 4160 Deichsel f. 374160

- 51 4184 Treibrad, links
- 51 4185 Treibrad isoliert, rechts
- 51 4186 Kuppelrad, links
- 51 4187 Kuppelrad isoliert, rechts
- 51 4188 Vorlaufrad
- 51 4189 Vorlaufrad, isoliert
- 54 4011 Achse
- 56 4772 Distanzring für 324166

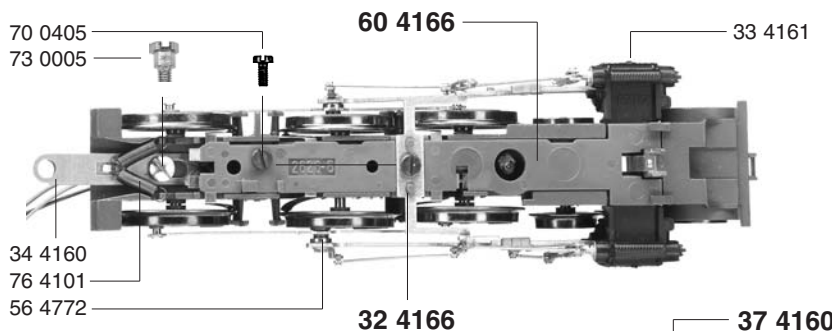

- 60 4166 Stromabnehmereinsatz
- 64 4403 Kontaktpilzgarnitur

- 70 0405 Schraube für 604166
- 71 3713 Schraube f. 104166
- 73 0005 Linsenschraube f. 344160
- 73 0008 Ansatzschraube f. 374160
- 73 0512 Bolzen f. Kuppelstange
- 75 4040 Steckpuffer, gewölbt
- 75 4041 Steckpuffer, flach
- 76 4101 Zugfeder für Tender-Kurzkupplung

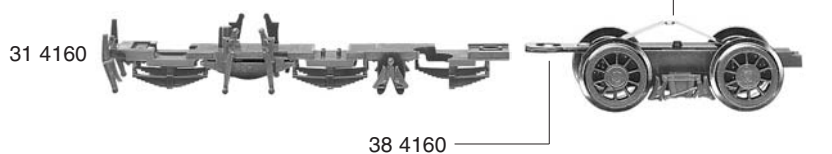

- 6509 Steckkupplung GFN
- 6515 PROFI-Steckkupplung
- 6535 Glühlampe

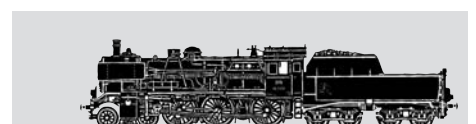
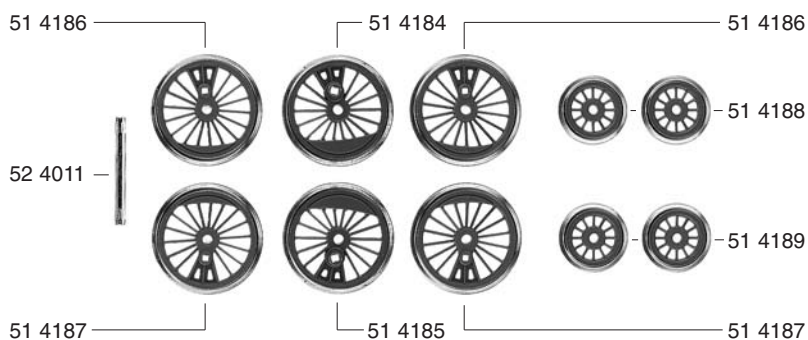



- 19 4801 Bremsschlauch
- 20 4166 Tendergehäuse kpl.
- 22 4162 Kleinteile f. Tender (Satz)
- 23 4179 Lichtleiter (Satz)
- 38 4015 Kuku-Deichsel
- 40 4166 Tenderfahrgestell kpl. ohne Motor
- 41 4166 Drehgestellrahmen mit Schienenräumer
- 41 4179 Drehgestellrahmen
- 50 4166 Motor
- 50 4902 Motorhalter
- 50 4909 Motorhalter m. Kontakten
- 51 4356 Tenderrad isol. o. Z. o. N.
- 51 4357 Tenderrad isol. o. Z. m. N.
- 51 4358 Tenderrad o. Z. o. N.
- 51 4359 Tenderrad o. Z. m. N.
- 52 4006 Achse, gekerbt
- 52 4011 Achse
- 54 4008 Haftreifen

20 4166

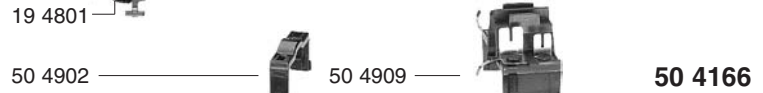

Motor ist wartungsfrei!

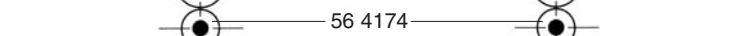
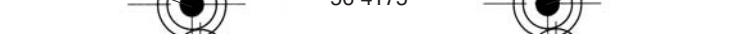
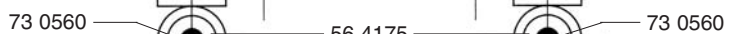
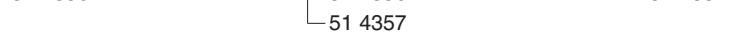
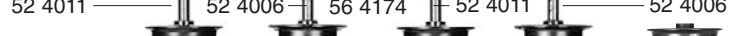
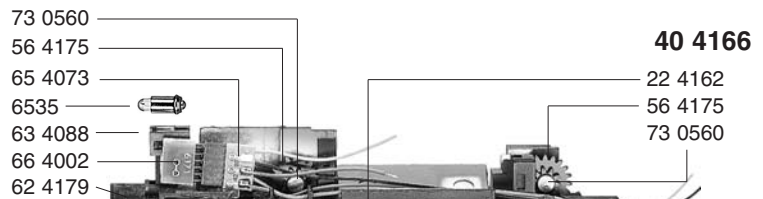

	Außen-Ø	Zähnezahl	Zähnezahl
56 4174 Zahnrad f. Radsatz	6	10	
56 4175 Doppelzahnrad	10,5	19	10
56 4176 Zahnrad	9	16	
56 4606 Schnecke			

- 62 4179 Beleuchtungsabdeckung
- 63 4088 Lampenkontakthalter
- 64 4202 Entstör-Kondensator
- 65 4073 Buchsenleiste f. Schnittstelle
- 65 4078 Schaltplatte kpl.
- 66 4002 Schnittstellen-Blindstecker, 6-polig
- 70 0403 Schraube f. 414179
- 70 0406 Schraube f. 414166
- 73 0003 Schraube f. 654078
- 73 0560 Bolzen f. Zahnrad 564175
- 73 0561 Bundbolzen f. 384015
- 75 4040 Steckpuffer gewölbt
- 75 4041 Steckpuffer, flach

- 6516 PROFIL-Schlitzkupplung
- 6520 GFN-Schlitzkupplung
- 6535 Glühlampe

