

Pos. Nr. Pos.no.	Beschreibung Description	Art.-N.r. Art.no.	Preisgruppe Price bracket
1	LOKGEHÄUSE BR64 DB Locomotive body BR 64 DB	104061822	031
2	LICHTLEITER-SATZ Light conductor set	00131063	012
3	BESCHWERUNG Ballast	00164063	016
4	PFEIFE Whistle	00194601	004
5	LEITERN-SATZ Set of ladders	00224175	011
6	LOKFAHRGESTELL M. MOTOR U. BESCHW. Chassis complete with motor&ballast	404061822	046
7	LOKFAHRGESTELL M. MOTOR, GETRIEB Chassis with motor and gear train	414061822	038
8	DECKPLATTE Cover plate	00414064	007
9	STEUERUNG KPL. M. KUPPELSTANGE Reversing gear complete with coupling rods	42406101	031
10	ZYLINDERKASTEN Cylinder box	00434062	011
11	LUFTKESSEL Air tank	00444064	006
12	KESSELSTÜTZE KPL. Boiler support, complete	00454063	013
13	VORLAUFGESTELL M. ANDRUCKSFEDER Carrying wheelset (front/rear) with pressure spring	00474063	015
14	ANKER KPL. M. SCHWUNGMASSE Rotor complete with integr. flywheel	00504607	025
15	LAGERSCHILD ISOL.M.SCHNITTST. Motor PCB, insulated, with interface	00504731	017
16	KOHLENROHRKAPPE Brush pipe cap	00504801	002
17	L. RAD F. VOR.-NACHLAUF ROT Carrying wheel for carrying wheelset front/rear red	00514218	006
18	KUPPELRAD LI. ROT Left coupled wheel, red paint	00514224	006
19	KUPPELRAD RECHTS ISO. ROT Right coupled wheel, insulated, red paint	00514226	007
20	L. RAD F. VOR.-NACHLAUF ISO. Locomotive wheel, insul., for carrying wheelset front/rear	00514228	007
21	L. RAD M.Z.O.N. Locomotive wheel with gear, w/o traction tyre	00514291	008
22	TREIBRAD RECHTS ISO. ROT Right driving wheel, insulated, red	00514292	008
23	TREIBRAD LINKS ROT Left driving wheel, red	00514293	008
24	ACHSE GERÄNDELT 20 MM Milled axle, 20mm	00524006	002
25	UNTERSETZUNGRAD Z:28/13 SCHWA Reduction gear wheel Z:28/13, black	00564102	002
26	ZAHNRAD Z:32 ROT Gear wheel Z:32, red	00564137	002
27	UNTERSETZUNGRAD Z:32/13 ROT Reduction gear wheel Z:32/13, red	00564138	002
28	RITZEL Z:15 Gear wheel Z:15	00564604	006
29	SICHERUNGRING GROSS Securing ring, big	00564702	001
30	UNTERLEGSCHWEIBE ROT 2,2X5X0,5 Washer, red 2.2X5X0.5	00564742	001
	UNTERLEGSCHWEIBE 2,3X5X0,1 (o. Abb.) Washer 2.3X5X0.1 (collector side) (w/o illustr.)	00564747	001
	UNTERLEGSCHWEIBE ROT 2,2X5X0,3 (o. Abb.) Washer, red 2.2X5X0.3 (gear side) (w/o illustr.)	00564751	001
33	STROMABNEMER ISO. Power pick-up assembly, insulated	00614021	008
34	KONTAKTFEDER Contact spring	00614914	002
35	LAMPENFASSUNG Lamp socket	00624064	012
36	ENTSTÖRDROSSEL Suppressor choke	00644101	007
37	SCHRAUBE Screw	00700313	001

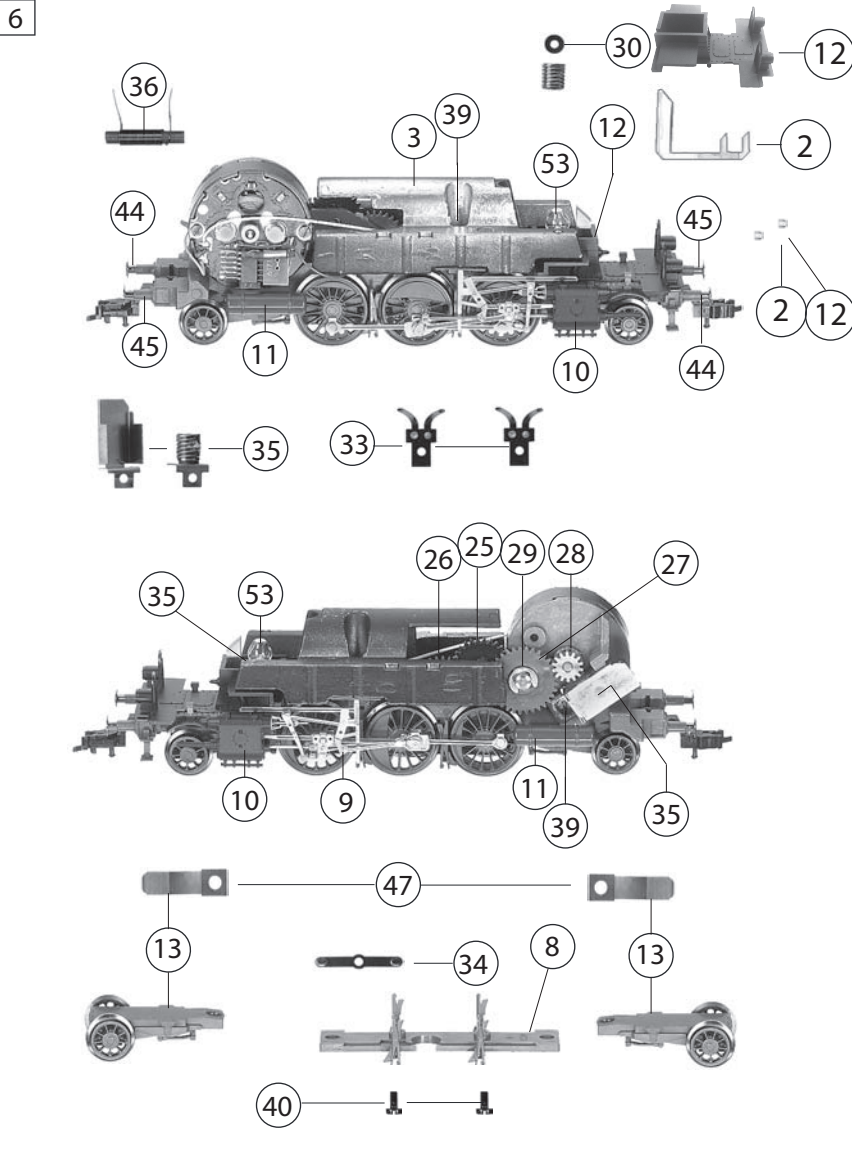

Pos. Nr. Pos.no.	Beschreibung Description	Art.-Nr. Art.no.	Preisgruppe Price bracket
38	ZYLINDERKOPFSCHRAUBE Cylinder head screw	00700403	001
	SCHRAUBE (o. Abb.) Screw (w/o illustr.)	00700405	001
40	SCHRAUBE Screw	00700408	001
	SCHRAUBE (o. Abb.) Screw (w/o illustr.)	00713516	001
42	SPLINT F. SCHLITZKPPPL. Split pin for coupling adaptor	00730503	001
43	BOLZEN FÜR KUPPELSTANGE Linkage pin for coupling rod	00730569	001
44	STECKPUFFER GEWÖLBT Plug-in buffer, curved	00754006	002
45	STECKPUFFER FLACH Plug-in buffer, flat	00754015	002
46	BLATTTRICHTFEDER L=14 MM Flat spring l=14mm	00764012	002
47	BLATTFEDER F. VORLAUFGEST Flat spring for carrying wheelset	00764307	005
48	DRUCKFEDER Pressure spring	00764310	001
49	PROFI-SCHLITZKUPPLUNG Profi slot coupling	6516	---
	ERSATZ-SCHLEIFKOHLEN (o. Abb.) Carbon brushes set (w/o illustration)	6519	---
	SCHLITZKUPPLUNG (o. Abb.) Slot coupling (w/o illustr.)	6520	---
	SCHLITZ- TAUSCHKUPPLUNG (o. Abb.) Slot exchange coupling (w/o illustr.)	6523	---
53	ERS. - GLÜHLAMPE M. SCHRAUBFAS. Spare bulb with screw base	00006530	007

