

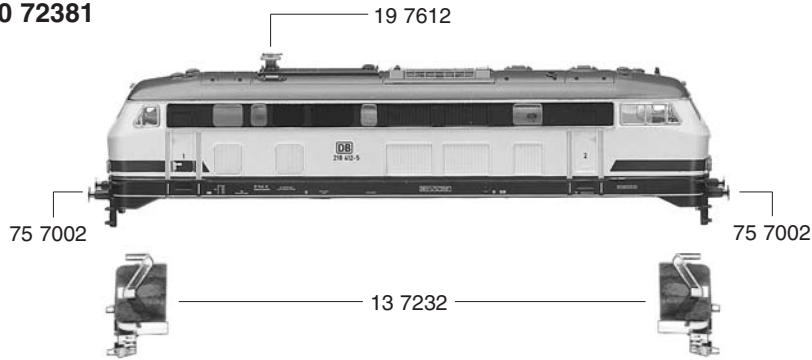

10 72381

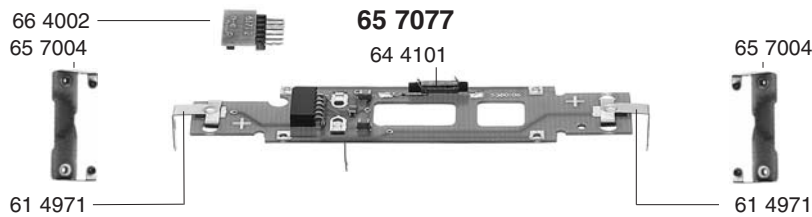

- 10 72381 Lokgehäuse kpl.
- 13 7232 Flutlichtleiter mit Abdeckblech
- 19 7612 Abgashutzen



- 40 7238 Lokfahrgestell o. Motor
- 41 7233 Drehgestellrahmen
- 45 7232 Drehgestellblock kpl. m. Stromabnehmer vorne
- 46 7232 Drehgestellblock kpl. m. Stromabnehmer hinten



- 50 7238 Motor kpl. m. Schwungmasse
- 52 7002 Achse f. 567101
- 56 7101 Zahnrad 20 Zähne, Außen - Ø 8,8 mm
- 56 7770 Rohr 4,1 mm lg., Ø 4,5 mm

40 7238

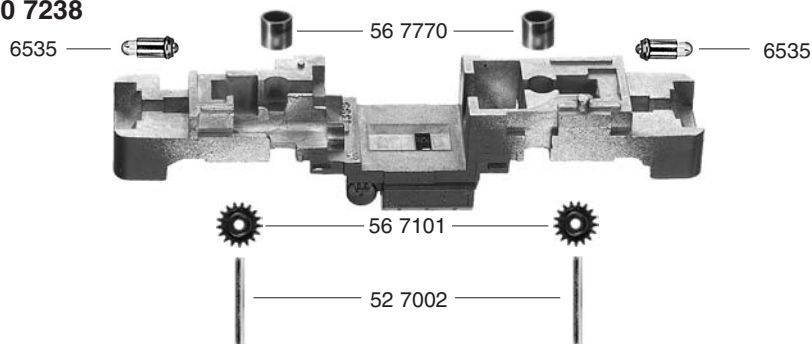

- 61 4971 Beleuchtungsfeder
- 64 4101 Entstör-Drossel
- 65 7004 Kontaktbügel
- 65 7077 Schaltplatte kpl. m. Schnittstelle
- 66 4002 Schnittstellen-Blindstecker, 6-polig

- 70 2303 Schraube f. Drehgestell
- 75 7002 Steckpuffer
- 76 7006 Richtfeder f. Kupplung

- 6535 Glühlampe
- 9521 Standard-Kupplung
- 9541 PROFI-Kupplung (o. Abb.)

45 7232



46 7232

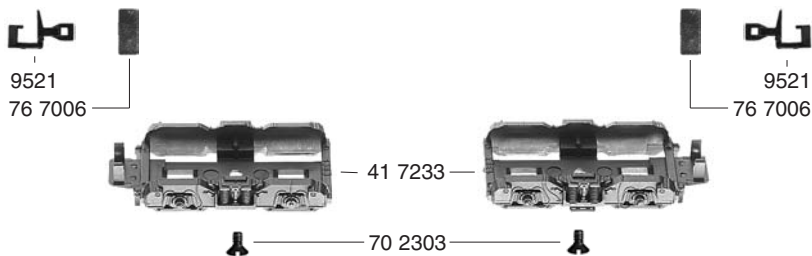

7238 FLEISCHMANN

ab Fertigung 2003 mit Schnittstelle



- 50 7238 Motor kpl. m. Schwung-
masse
- 50 7801 Kohlehalter
- 53 7016 Radsatz kpl. m. Z. o. N.
- 53 7048 Radsatz kpl. m. Z. m. N.
- 54 7001 Haftreifen
- 56 7601 Schnecke

6518 Kohlen und Federn

