

Pos. Nr. Pos. no.	Beschreibung Description	Art.-Nr. Art. no.	Preisgruppe Price bracket
874226 BR V60 DBAG 363159-5 = HO			
1	Lokgehäuse kpl. (n. lieferbar) Body assembly complete (not available)		
2	LICHTLEITER-SATZ Light conductor set	00134225	011
3	LICHTLEITER ABDECK. Lamp housing	00144224	004
4	BESCHWERUNG Ballast	00164225	012
5	HORN F.4223 Signal horn	00194620	003
6	ANTENNE F.4223,-24,-25 Antenna	00194701	004
7	FAHRGESTELL MIT MOTOR (n. lieferbar) Chassis complete with motor (not available)		---
8	KUPPELSTANGE F.4223 (rot) Coupling rod (red)	00424223	006
9	BUEHNENGELAENDER F.4224 Platform hand rail	00444224	008
10	SEITENGELAENDER-SATZ F.4223/24 Side platform rails -set	00454224	014
11	MOTOR M.SCHWUNGMASSE F.4226 SS Motor with flywheel	00504226	033
12	ANKER KPL.M.SCHWUNGMASSE Rotor, complete with flywheel	00504607	025
13	LAGERSCHILD ISO.M.SCHNITTST. Motor PCB, insulated, with interface	00504738	019
14	KOHLENROHRKAPPE Brush pipe cap	00504801	002
15	LOETOESE Soldering tag	00504852	001
16	KUPPELRAD M.Z.F.4223 (n. lieferbar) Coupled wheel with gear (not available)		
17	KUPPELRAD O.Z.ISO.F.4223 (n. lieferbar) Coupled wheel w/o gear, insulated (n. available)		
18	KUPPELRAD O.Z.F.4223 (n. lieferbar) Coupled wheel w/o gear (not available)		
19	BLINDWELLE SCHWARZ F.4223 (n. lieferbar) Jackshaft (not available)		
20	ACHSE SCHW. VERN. Axle	52401700	---
21	ACHSE schw.vern. Axle	52401800	---
22	UNTERSETZUNGSRAD Z:28/13 SCHWA Reduction gear wheel Z:28/13, black	00564102	002
23	ZAHNRAD Z:32 SCHWARZ Gear wheel Z:32, black	00564108	003
24	RITZEL ERS.F.564601 Z:12 MESSI Brass gear wheel, Z:12	00564603	004
25	SICHERUNGSRING KLEIN Securing ring, small	00564701	001
26	SICHERUNGSSCHEIBE 3,2 schw.gef Securing washer 3.2, black	56470700	---
	U-SCHEIBE schw.vern. (o. Abb.) Washer (w/o illustr.)	56475600	---
	UNTERLEGSCH. 2,3 X 5 X 0,1 (o. Abb.) Washer (w/o illustr.)	00564747	001
	UNTERLEGSCH.ROT 2,2X5X0,3 (o. Abb.) Washer (w/o illustr.)	00564751	001
30	STROMABNEHMER DOPPELT, ISO. Double power pick-up, insulated	00614003	008
31	STROMABNEHMER EINFACH, ISO Single power pick-up, insulated	00614011	009
32	KONTAKTFEDER F.BR 260 U.614 Contacter spring	00614906	006
33	LAMPENHALTER F."V 60 U.V 100" Lamp support	00624335	011
34	ENTSTOERDROSSEL Suppressor choke	00644101	007
35	KONDENSATOR Capacitor	64420900	005
36	KONTAKTPILZGARNITUR L:10 MM Contacter pin assembly	00644401	011
37	SCHNITTST.-BLINDSTECKER 6-POL. Jumper, 6-pin	00664002	013

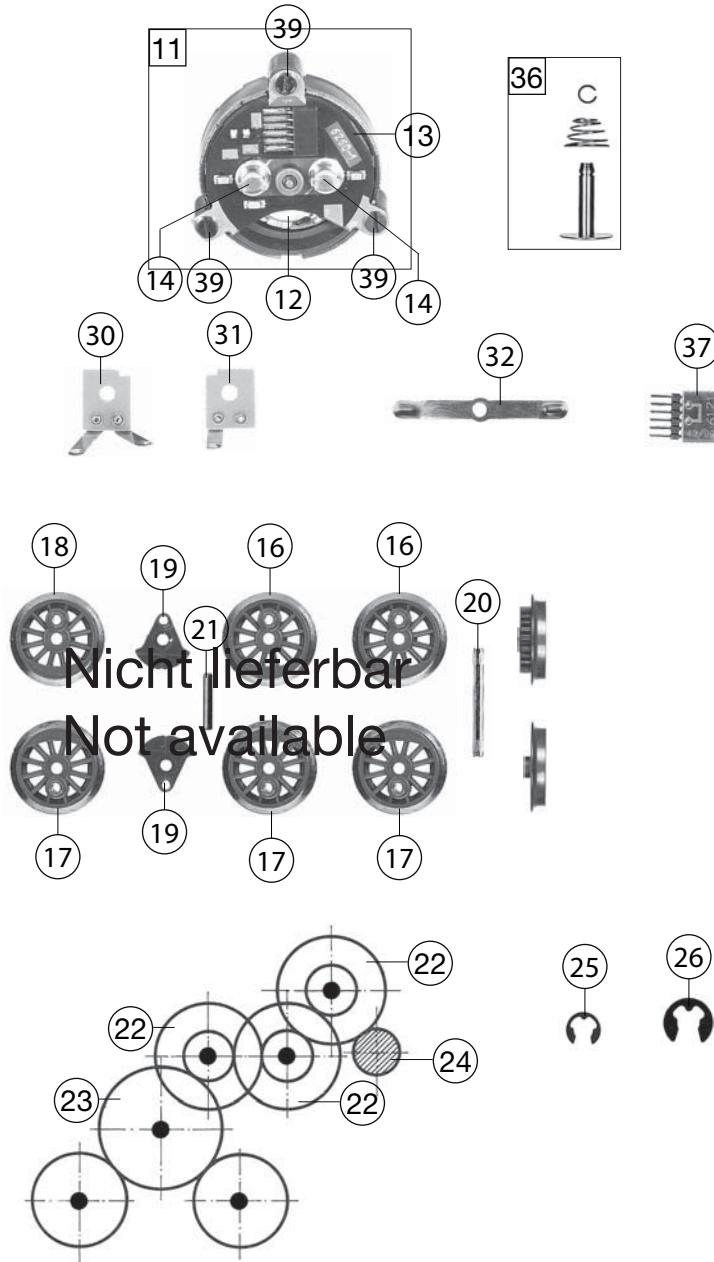

874226		BR V60 DBAG	363159-5	=	HO
Pos. Nr. Pos.no.	Beschreibung Description	Art.-Nr. Art.no.	Preisgruppe Price bracket		
38	ZYLINDERKOPFSCHRAUBE Cylinder head screw	00700403	001		
39	SCHRAUBE Screw	00700412	001		
40	SECHSKANTSCHRAUBE F.4223 Hex screw	00730039	001		
41	SPLINT F. SCHLITZKPL. Split pin for slot coupling	00730503	001		
42	SCHRAUBPUFFER KURZ GEW.3 MM Screw-in buffer, short, 3 mm metric thread	00754001	002		
43	BLATTRICHTFEDER L=14 MM Flat straightening spring l=14mm	00764012	002		
	PROFI-SCHLITZKUPPLUNG (o. Abb.) Profi slot coupling (w/o illustr.)	6516	---		
	ERSATZ-SCHLEIFKOHLEN (o. Abb.) Carbon brushes set (w/o illustr.)	6519	---		
	FLEISCHMANN SCHLITZ-KUPPLUNG (o. Abb.) Fleischmann slot coupling (w/o illustr.)	6520	---		
	SCHLITZ-TAUSCHKUPPLUNG (o. Abb.) Standard slot coupling (w/o illustr.)	6523	---		
48	ERS.-GLÜHLAMPE M.SCHRAUBFAS. Spare bulb with screw base	00006530	007		